

Development of an Automated Coffee Bean Dryer Using Arduino Uno for Efficient Moisture Control

Suryadi¹, Faisal Ihfani², Khoirul Yazid³

^a Department of Electrical, Padang State Polytechnic, Padang City, 20362, Indonesia
Padang State Polytechnic, Padang City, 20362, Indonesia

Corresponding author: Suryadi@pnp.ac.id

Abstract— This study focuses on the development and evaluation of an automated coffee bean dryer utilizing the Arduino Uno microcontroller. The primary objective of the research is to reduce the moisture content of Robusta coffee beans to below 12%, a critical threshold for preventing mold growth, within a significantly reduced timeframe compared to traditional sun-drying methods. The materials used in this study include an Arduino Uno microcontroller, a DHT11 sensor for monitoring temperature and humidity, and incandescent lamps as the heat source. The method involved designing, building, and testing the dryer, followed by data collection through multiple trials. The temperature and humidity inside the drying chamber were continuously monitored, and the weight of the coffee beans was measured at regular intervals to calculate moisture loss. The results showed that the system successfully reduced the moisture content to 12.4% within 8 hours and 40 minutes, a significant improvement over the conventional drying time of 5-7 days. The automated system provides greater control over environmental conditions, ensuring consistent drying performance. This research highlights the potential of automation to enhance efficiency and productivity in coffee processing, particularly in regions with inconsistent weather conditions. Future research could focus on improving energy efficiency and scaling the system for larger production capacities.

Keywords— arduino uno; automated coffee dryer; coffee bean drying; DHT11 sensor; humidity control; moisture content; robusta coffee; temperature control.

Manuscript received 28 Sept. 2024; revised 21 Nov. 2024; accepted 12 Jan. 2025. Date of publication 3 Mei. 2025.

International Journal of Wireless And Multimedia Communications is licensed under a Creative Commons Attribution-Share Alike 4.0 International License



I. INTRODUCTION

Coffee is one of the leading plantation commodities in Indonesia, contributing significantly to the country's foreign exchange, providing a source of income for farmers, raw materials for industries, job creation, and regional development (Baso & Anindita, 2018). Among the most well-known coffee varieties is Robusta, which is characterized by its stronger, more bitter taste and higher caffeine content compared to Arabica (Nestle & Nescafe, 2022). However, the production process, particularly during the drying stage, is still predominantly done using conventional sun-drying methods, which are highly dependent on weather conditions.

The optimal moisture content for Robusta coffee beans should be below 12% to avoid the growth of molds such as *Aspergillus ochraceus* and *Penicillium*. Unfortunately, in Indonesia, particularly in Kerinci, Jambi, frequent rainfall

makes the sun-drying process inefficient, resulting in coffee beans with moisture levels that often exceed 12%, putting them at risk for mold contamination (Susila, 2005). Thus, there is a need for a more efficient drying method that can operate continuously, regardless of weather conditions.

Recent technological advancements, particularly in microcontroller-based systems like the Arduino Uno, provide opportunities to develop automated coffee bean drying equipment. This research focuses on designing and implementing an automatic coffee bean dryer using the Arduino Uno microcontroller and incandescent lamps as a heat source, replacing sunlight. By incorporating a DHT11 sensor, the device is capable of controlling the temperature and humidity levels within the drying chamber to meet the necessary standards for coffee drying.

The objective of this study is to evaluate the efficiency of the automated dryer in reducing the moisture content of Robusta

coffee beans to below 12% and to compare its performance with conventional sun-drying methods. It is expected that this system will help coffee farmers and processors, especially in high-rainfall areas like Kerinci, improve the drying process and overall efficiency.

II. METHOD

2.1 Research Methods

This study adopts a quantitative experimental research method, focusing on the design and testing of an automated coffee bean drying system. The system is built around the Arduino Uno microcontroller, which manages the drying process by controlling a heat source (incandescent lamps) and monitoring environmental conditions using a DHT11 sensor. The primary goal is to assess the system's ability to reduce the moisture content of Robusta coffee beans to below 12%, a critical threshold for preventing mold growth. The research proceeds through several stages, including system design, data collection, data processing, and result analysis, each of which is essential for evaluating the system's efficiency and effectiveness.

The experimental setup enables direct comparison between the automated drying method and traditional sun-drying, allowing for an assessment of time efficiency, energy consumption, and overall performance in maintaining the quality of the coffee beans. The entire system is tested under controlled conditions to simulate real-world environments, with data collected at multiple stages of the drying process.

2.2 Literature Review

The literature review plays a crucial role in this research by establishing a foundation based on existing theories and technologies related to coffee drying and automation. The study draws heavily from recent articles published between 2019 and 2022 to ensure that the methodologies employed are aligned with current technological advancements. Special emphasis is placed on the use of microcontrollers like the Arduino Uno, which has been widely adopted in various fields for controlling and automating processes due to its versatility and ease of programming.

In addition to exploring the mechanics of coffee drying, the literature review also investigates the biological factors affecting coffee beans, particularly the risks associated with improper drying. Studies indicate that mold, including *Aspergillus ochraceus* and *Penicillium*, tends to grow when moisture content exceeds 12% (Susila, 2005). These insights shape the parameters for the drying system, particularly the temperature and humidity ranges that need to be maintained to prevent spoilage. The gathered knowledge informs the development of both the hardware and software components of the dryer, ensuring they are designed to meet the specific requirements of coffee drying.

2.3 Equipment Design

The design and development of the automatic coffee bean dryer involve a combination of hardware and software components. The system's hardware includes an Arduino Uno microcontroller, which acts as the central control unit, a DHT11 sensor for monitoring temperature and humidity, incandescent lamps as the heat source, and a relay to switch the heating element on and off. The layout of the components is illustrated

in *Figure 1*, which provides a block diagram of the system. Each component is strategically placed to optimize the efficiency of the drying process, ensuring uniform heat distribution throughout the drying chamber.

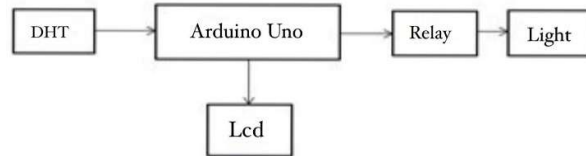

Fig. 1 Block Diagram of the Coffee Dryer System

The physical structure of the dryer is constructed using plywood with an interior lined with aluminum foil to improve heat retention. The drying chamber is designed to accommodate a perforated wire tray, which holds the coffee beans and allows for even air circulation, ensuring that the beans are exposed to consistent heat levels. The construction is depicted in *Figure 2*, which shows both front and side views of the dryer. *Table 1* provides details of the pin connections between the Arduino Uno and the various components, including the DHT11 sensor, LCD display, and relay.

TABLE 1
Pin Connections of All Components

Module	Pin Module	Pin NodeMCU
LCD I2C	VCC	5V
	GND	GND
	SDA	A4
	SCL	A5
DH11	VCC	3.3V
	GND	GND
	DATA	D2
RELAY	VCC	5V
	GND	GND
	IN1	D3
	IN2	D4

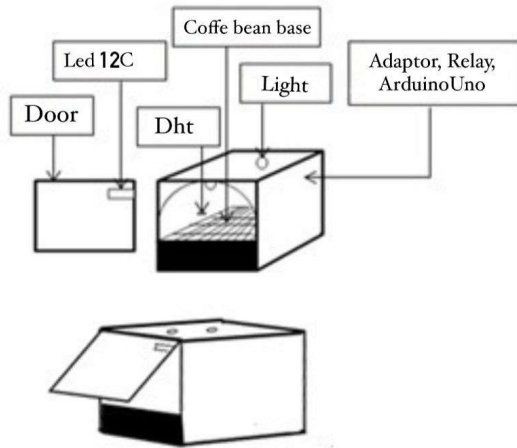

Fig. 2 Front and Side View of the Dryer Equipment

The system's software is developed using Arduino IDE, which allows for easy programming and control of the hardware components. A flowchart of the control program, shown in Figure 3, outlines the process by which the sensor readings are used to activate or deactivate the heating elements based on the temperature and humidity inside the drying chamber. The DHT11 sensor continuously monitors these environmental factors, and the system adjusts the operation of the incandescent lamps to maintain optimal drying conditions.

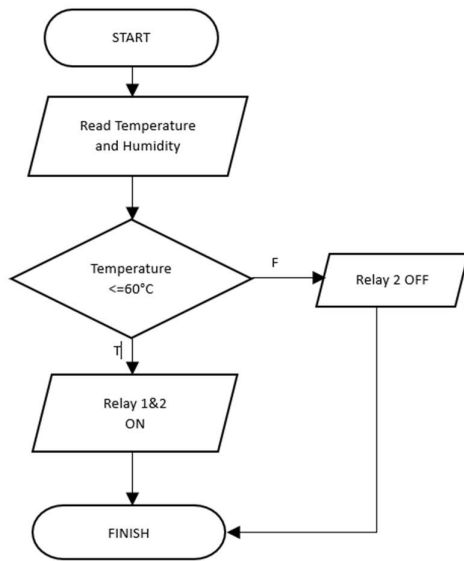

Fig. 3 Flowchart of the Program in Arduino IDE

2.4 Data Retrieval

Data collection is a critical phase in this research, as it provides the empirical evidence needed to evaluate the performance of the drying system. For the experiments, Robusta coffee beans were selected due to their high prevalence in Indonesia. An initial batch of beans, weighing 119.2 g, was placed in the drying chamber. The initial moisture content of the beans was assumed to be greater than 12%, as is typical for freshly harvested beans.

The DHT11 sensor was programmed to record temperature and humidity data at one-hour intervals throughout the drying process. The data were displayed on an LCD screen connected to the Arduino Uno, providing real-time monitoring of the drying conditions. In addition to environmental data, the weight of the beans was measured periodically using a digital scale to track the reduction in moisture content over time. Table 2 provides a summary of the weight and moisture content measurements taken at each stage of the experiment, while Figure 4 shows the wiring of the DHT11 sensor to the microcontroller.

TABLE 2

Weight and Moisture Content Results				
trial	Initial weight(g)	Final weight(g)	Moisture Loss (g)	Drying time(hrs)
1	119.2	74.9	44.3	3.25
2	74.9	42.8	32.1	3.25
3	42.8	37.6	5.2	2.0

TABLE 3

Weight and Moisture Content Results (humidity and temperature)

Trial	Humidity (%)	Temperature (°C)
1	46	60
2	24	60
3	19	60

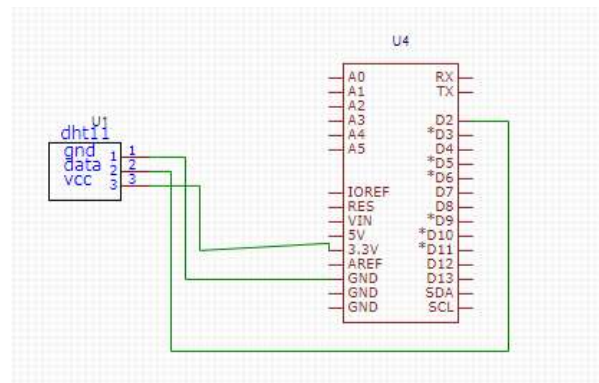

Fig. 4 Wiring Diagram of DHT11 Sensor with Microcontroller

2.5 Data Processing

Once the data were collected, the next step was processing it to calculate the reduction in moisture content. The formula used to calculate the moisture content is as follows:

$$\% \text{ Moisture Content} = \frac{W - W1}{W} \times 100$$

Where:

- **W** is the initial weight of the beans before drying.
- **W1** is the final weight of the beans after drying.

The temperature and humidity data, along with the weight measurements, were analyzed to determine the effectiveness of the drying process. Table 7 shows the results of temperature

measurements taken during the experiment. The data were then plotted on graphs to visualize the relationship between the environmental conditions and the drying rate. The drying time and energy consumption of the system were also compared to traditional sun-drying methods to evaluate the benefits of automation.

TABLE 4

Temperature Measurement Results Using DHT11 Sensor	
DHT11 temperature testing	Temperature testing of Thermometer
34.00°C	34,4 °C
36.00 °C	35,6 °C
38.00 °C	39,8 °C
40.00 °C	40,2 °C
42.00 °C	42,2 °C

2.6 Results Analysis

The analysis of the results involved comparing the performance of the automatic drying system to conventional sun-drying methods. The key metrics for comparison included the time required to achieve a moisture content of less than 12%, the stability of temperature and humidity levels within the drying chamber, and the overall energy consumption of the system. The drying system was able to reduce the moisture content of the coffee beans to 12.4% in 8 hours and 40 minutes, a significant improvement over the 5-7 days typically required for sun-drying.

The energy efficiency of the system was also assessed by measuring the power consumption of the incandescent lamps throughout the drying process. *Figure 5* and *Figure 6* depict the condition of the beans before and after drying, illustrating the physical changes that occurred during the experiment. These results, combined with the data from *Table 3*, demonstrate the effectiveness of the automated system in achieving the desired moisture levels more quickly and efficiently than traditional methods.



Fig. 5 Coffee Beans during Drying Process



Fig. 6 Weight of Coffee Beans after Second Drying

III. RESULT AND DISCUSSION

3.1 Results

The primary objective of this research was to assess the effectiveness of the automated coffee bean dryer in reducing the moisture content of Robusta coffee beans. The system was tested through three trials, with the initial weight of the beans and their moisture content monitored at specific intervals. *Table 3* provides a summary of the key measurements taken during each trial, including the initial and final weight of the beans, moisture loss, drying time, humidity, and temperature.

3.1.1 Drying Time and Moisture Reduction

In the first trial, the initial weight of the beans was 119.2 g, with a moisture content exceeding 12%. After 3.25 hours of drying at a temperature of 60°C and humidity of 46%, the beans' final weight was 74.9 g, reflecting a moisture loss of 44.3 g. The second trial began with 74.9 g of beans and, after another 3.25 hours, the weight was reduced to 42.8 g, with a 32.1 g moisture loss. Finally, in the third trial, the beans were dried for an additional 2 hours, resulting in a final weight of 37.6 g.

The total drying time for the three trials was approximately 8 hours and 40 minutes, during which the moisture content was reduced to 12.4%. This was achieved under controlled conditions where the temperature was maintained at 60°C, and humidity varied between 19% and 46%. *Figure 5* and *Figure 6* illustrate the physical state of the coffee beans before and after the drying process, highlighting the shrinkage in size and changes in texture due to moisture loss.

3.2 Discussion

3.2.1 Efficiency of Automated Drying System

The results demonstrate that the automated coffee dryer successfully reduced the moisture content of Robusta coffee beans to below 12%, which is essential for preventing mold growth. Compared to traditional sun-drying methods, which typically require 5 to 7 days to achieve similar moisture levels, the automated system completed the drying process in less than 9 hours. This represents a significant reduction in drying time,

improving the efficiency of the coffee production process, especially in regions with inconsistent sunlight, such as Kerinci.

One of the key advantages of the automated system is its ability to maintain a constant temperature throughout the drying process. The use of a DHT11 sensor allowed for continuous monitoring of temperature and humidity, ensuring that the drying environment remained stable. The system's performance was consistent across all three trials, with the temperature held at 60°C and humidity decreasing progressively, as shown in *Table 3*. This stability is difficult to achieve with sun-drying methods, which are highly dependent on weather conditions.

3.2.2 Impact of Temperature and Humidity

Temperature and humidity play crucial roles in the drying process. In this study, a constant temperature of 60°C was maintained, as previous research has indicated that this range is optimal for drying coffee beans without causing damage to their structure (Sihombing et al., 2022). The reduction in humidity levels, from 46% in the first trial to 19% in the final trial, further enhanced the drying process by promoting faster evaporation of moisture from the beans.

The use of incandescent lamps as a heat source was effective, with the system's relay controlling the lamps' operation based on the sensor readings. The energy consumption of the lamps was monitored, and while incandescent lamps are known to be less energy-efficient than other heating options, they provided sufficient heat for the drying process. Future iterations of the system could explore the use of more energy-efficient heating elements, such as infrared or halogen lamps, to further reduce energy consumption.

3.2.3 Comparison with Traditional Methods

Traditional sun-drying methods, though widely used, have several limitations, including dependency on weather conditions and longer drying times. In comparison, the automated dryer offers significant advantages in terms of time efficiency and control over environmental conditions. By maintaining a constant temperature and lowering humidity levels in a controlled environment, the automated system produced coffee beans with a final moisture content of 12.4%, well within the acceptable range for preventing spoilage.

Moreover, the system's ability to operate regardless of external weather conditions makes it particularly useful in regions like Kerinci, where high rainfall and fluctuating temperatures can disrupt the sun-drying process. The results confirm that the automated drying system provides a reliable and efficient alternative to traditional methods, potentially increasing productivity for coffee farmers and processors.

3.2.4 Potential for Future Improvements

While the results of this study are promising, there are several areas where the system could be improved. First, the use of more energy-efficient heat sources could reduce the operational costs of the system. Second, increasing the size of the drying chamber would allow for larger batches of coffee beans to be processed simultaneously, improving overall throughput. Additionally, integrating more advanced sensors for monitoring additional variables, such as airflow, could enhance the precision and efficiency of the drying process.

IV. CONCLUSION

The development and testing of the automated coffee bean dryer using the Arduino Uno microcontroller demonstrated a significant improvement in the efficiency and effectiveness of the drying process. The system successfully reduced the moisture content of Robusta coffee beans to 12.4% in less than 9 hours, compared to the 5-7 days typically required for traditional sun-drying methods. This substantial reduction in drying time highlights the potential of automated systems to improve coffee production processes, particularly in regions with inconsistent sunlight, such as Kerinci.

Key factors contributing to the system's success include the consistent temperature control provided by the DHT11 sensor and the stable operation of the incandescent lamps as a heat source. By maintaining a constant drying temperature of 60°C and lowering humidity levels, the system effectively promoted moisture evaporation while preserving the quality of the coffee beans. The results also confirmed that automated drying can overcome many of the challenges associated with traditional sun-drying, such as weather dependency and uneven drying.

While the current system showed promising results, there is room for future improvements. Incorporating more energy-efficient heat sources, such as infrared lamps, and scaling up the size of the drying chamber could further enhance the system's performance. Additionally, integrating more advanced environmental sensors could provide more precise control over the drying conditions, improving the quality of the final product.

In conclusion, the automated coffee bean dryer presents a viable alternative to traditional drying methods, offering enhanced efficiency, reduced drying time, and better control over environmental conditions. This system has the potential to significantly benefit coffee farmers and processors, particularly in regions with challenging climatic conditions, by increasing productivity and ensuring the consistent quality of dried coffee beans.

REFERENCES

- [1] R. L. Baso and R. Anindita, "Analysis of Competitiveness Indonesia's Coffee," *J. Ekonomi Pertanian dan Agribisnis (JEPA)*, vol. 2, no. 1, pp. 1–9, 2018.
- [2] W. R. Susila, "Targeted Study of the Arabica Coffee Production Chain in North Sumatra (The Mandheling Coffee)," *National Consultant Report, Food and Agriculture Organization*, 2005.
- [3] P. Afdholli, "Rancang Bangun Alat Pengering Biji Kopi Otomatis Berbasis Mikrokontroler," *Undergraduate thesis, Universitas Andalas, Padang, Indonesia*, 2018.
- [4] Data Desa, "Desa Jernih Jaya, Kabupaten Kerinci," *Sikampung Unja*, accessed August 7, 2023. [Online]. Available: <https://sikampung.unja.ac.id/data-des/>.
- [5] Arduino, "Product Reference Manual," accessed July 27, 2023. [Online]. Available:

- <https://docs.arduino.cc/static/70bfad900ad9ea1585e15ff70068ad38/A000066-datasheet.pdf>.
- [6] E. Yani and S. Fajrin, "Karakteristik Pengeringan Biji Kopi Berdasarkan Variasi Kecepatan Aliran Udara pada Solar Dryer," *J. Eng.*, vol. 20, 2013.
- [7] B. S. Sihombing, I. O. Kirana, Poningsih, and Irawan, "Rancang Bangun Alat Pengering Biji Kopi Berbasis Mikrokontroler Arduino Uno," *Storage: J. Ilmiah Teknik dan Ilmu Komputer*, vol. 1, no. 1, pp. 8-15, 2022. [Online]. Available: <https://doi.org/10.55123/storage.v1i1.155>.
- [8] A. W. Audrei, "Comparison of Different Types of Lamps and Electricity Savings," *Kompas*, Nov. 5, 2021.
- [9] M. Ahmad, "Koperasi Koerintji Barokah," *Personal Interview*, 2023.
- [10] Heri Andrianto dan Aan Darmawan (2016). *Arduino Belajar Cepat dan Pemrograman*. Informatika, Bandung.
- [11] Abdul Kadir (2018), *Arduino dan Sensor*, Andi Ofset, Yogyakarta
- [12] Yuwono Martadinata., (2016). *Arduno itu Pintar ,PT Elex Media Komputindo*, Jakarta
- [13] Harlod Timmis (2011). *Practical Arduino Engineering*. Apress 1st edition.
- [14] Hari Santoso (2015). *Panduan Praktis Arduino untuk Pemula*. Elang Sakti. Malang
- [15] L. . F. A. Caesar Pats Yahwe, Isnawaty, "Rancang Bangun Prototype System Monitoring Kelembaban Tanah Melalui Sms Berdasarkan Hasil Penyiraman Tanaman System Monitoring Kelembaban Tanah Melalui Sms Berdasarkan Hasil Penyiraman Tanaman," *semanTIK*, vol. Vol 2, no. 1, pp. 97-110, 2016.
- [16] A. Obidiwe, C. Ihekweaba, and P. Aguodoh, *Design and Implementation of a Microcontroller Based Egg Incubator with Digital Temperature read out*, in *Proceedings of the International Conference on Embedded Systems, Cyber-physical Systems, and Applications, ESCS (2014)*
- [17] W. S. M. Sanjaya et al., *The development of quail eggs smart incubator for hatching system based on microcontroller and Internet of Things (IoT)*, in *Proceedings of the 2018 International Conference on Information and Communications Technology, ICOIACT (2018)*
- [18] K. Radhakrishnan, N. Jose, S. S. G. T. Cherian, and V. K. R., *IJAREEIE* 3297 (2007)
- [19] G. V. Kutsira, N. I. Nwulu, and E. M. Dogo, *Development of a Small Scaled Microcontroller-Based Poultry Egg Incubation System*, in *Proceedings of the 2019 International Conference on Artificial Intelligence and Data Processing Symposium, IDAP, 21-22 Sept 2019, Turkey (2019)*
- [20] K. Chitra, T. Kalpana, M. Hemalatha, S. Hari Vishnu, K. Kishore, and S. Manoj, *Automatic Egg Incubator Using IoT*, in *Proceedings of the 2023 International*

Conference on Computer Communication and Informatics, ICCCI (2023)